

MODEL 8400 AMPLIFIER – APPLICATION EXAMPLE #2

STEREO HIGH IMPACT INVISIBLE SYSTEM WITH SUBWOOFERS (BRIDGED MODE OPERATION)

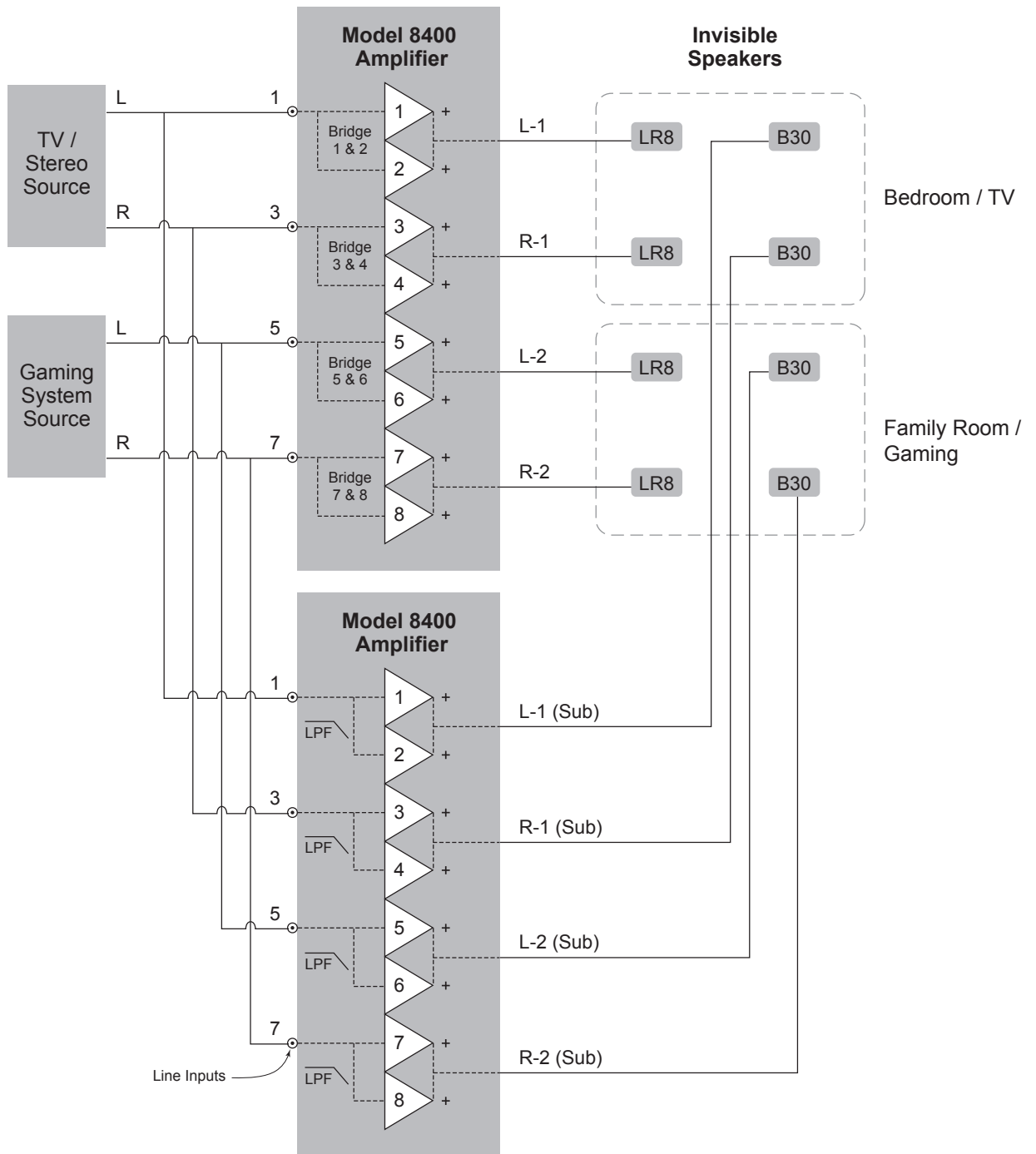

NOTES:

- Use this configuration for 2.2 TV applications or systems that require louder sound output and extended bass response (subwoofers).
- Turn **BRIDGE** mode ON for adjacent amplifier channels using front panel controls or handheld remote control.
- Use ODD number **LINE INPUT** jack for signals into bridged amplifiers.
- Connect speaker wires to (+) terminal of ODD channel and (+) terminal of EVEN channels when using bridged channels.
- Assign B30 **OPTIMIZATION** to subwoofer amp channels to engage low-pass filtering on subs. Use **BASS** tone control to remove lows from full-range speakers for maximum clarity.
- This configuration example provides 160W per speaker.
- This example may also utilize LR6 speakers with B22 subwoofers.
- Use **DELAY** function on amp channels to time system between speakers and subwoofers.